

# Wheel Bearing



Product competence from EUROPART

- Insert Unit (IU)
- Standard Tapered Roller Bearing (TRB)
- Repair Insert Unit (RIU)
- FAG SmartSET
- Truck Axle Module (TAM)
- Truck Hub Unit (THU)
- Tools/  
Workshop requirements
- Lubrication



## Standard Tapered Roller Bearing (TRB)



### Product description:

Tapered roller bearings bear high loads in a small installation space and exhibit good behaviour when cornering. They have been in use for over 100 years as the classical wheel bearing for commercial vehicles. They consist of an outer ring, and inner ring with rolling element and a cage. The outer ring and inner ring are removed and installed separately. Single-row tapered roller bearings are neither lubricated nor sealed. The bearing must be lubricated with suitable grease before installation. Regular removal of the hub due to maintenance, e.g. on the brake system, has a negative impact on the life of the tapered roller bearing:

- Penetration of dirt
- Improper re-lubrication
- Destruction of the seals
- Complicated re-adjustment of the bearing pair

### Note:

For safety reasons and to prevent potential consequential damage, the inner and outer tapered roller bearings must always be replaced when replacing the wheel bearing! Furthermore, the wheel must be turned opposite to the direction of tightening during the adjustment process or tensioning.

### Assembly:

1. Clean wheel hub and check for oval deformation
2. Lubricate bearing inner ring, rolling element and cage with suitable grease
3. Press the outer bearing shell into the wheel hub
4. Position the greased inner rings with rollers and cage into the wheel hub
5. Insert the shaft seals to seal the wheel hub using a suitable tool
6. Position the wheel hub on the axle shaft
7. Secure the axle nuts and adjust the bearings according to the manufacturer's instructions



## Tapered roller bearing

Type	Outer $\varnothing$	Inner $\varnothing$	Height	Order no
302 04A	47 mm	20 mm	15,25 mm	8001 302 042
30205-XL	52 mm	25 mm	16,25 mm	8001 302 052
302 06A	62 mm	30 mm	17,25 mm	8001 302 062
302 07A	72 mm	35 mm	18,25 mm	8001 302 072
320 14XA	110 mm	70 mm	25 mm	8001 320 142
320 19XA	145 mm	95 mm	32 mm	8001 320 192
320 20X	150 mm	100 mm	32 mm	8001 320 202
320 21X	160 mm	105 mm	35 mm	8001 320 212
322 12A	110 mm	60 mm	29,75 mm	8001 322 122
322 17A	150 mm	85 mm	38,5 mm	8001 322 172
323 09A	100 mm	45 mm	38,25 mm	8001 323 092
323 10A	110 mm	50 mm	42,25 mm	8001 323 102
323 11A	120 mm	55 mm	45,5 mm	8001 323 112
323 12A	130 mm	60 mm	48,5 mm	8001 323 122
32314A	150 mm	70 mm	54 mm	8001 323 142
330 19	145 mm	95 mm	39 mm	8001 330 192
330 20	150 mm	100 mm	39 mm	8001 330 202
330 21	160 mm	105 mm	43 mm	8001 330 212
330 22	170 mm	110 mm	47 mm	8001 330 222
331 13	110 mm	65 mm	34 mm	8001 331 132
331 16	130 mm	80 mm	37 mm	8001 331 162
331 18	150 mm	90 mm	45 mm	8001 331 182
332 08	80 mm	40 mm	32 mm	8001 332 082
332 13	120 mm	65 mm	41 mm	8001 332 132
332 15	130 mm	75 mm	41 mm	8001 332 152
332 17	150 mm	85 mm	49 mm	8001 332 172
332330	130 mm	70 mm	57 mm	8001 332 332
528 983	130 mm	70 mm	57,5 mm	8015 289 832
KHM218248-HM218210	147 mm	90 mm	40 mm	8012 102 482

**FAG****Tapered roller bearing**

Outer $\varnothing$	Inner $\varnothing$	Width	Order no	Comparative no
90 mm	38 mm	35 mm	<b>2625 438 050</b>	FAG 543805
157 mm	100 mm	42 mm	<b>9469 812 305</b>	FAG 567549
160 mm	100 mm	44 mm	<b>8001 805 312</b>	FAG 805312

**SKF****Tapered roller bearing**

Outer $\varnothing$	Inner $\varnothing$	Width	Order no	Comparative no
112,7 mm	57,1 mm	30,1 mm	<b>6000 139 520</b>	SKF VKHB 2088
160 mm	105 mm	43 mm	<b>8001 330 213</b>	SKF VKHB 2146
100 mm	55 mm	40 mm	<b>8001 328 251</b>	SKF VKHB 2240
150 mm	70 mm	64 mm	<b>8001 228 000</b>	SKF VKHB 2280
140 mm	82 mm	37,5 mm	<b>7600 000 342</b>	SKF VKHB 2315
165 mm	110 mm	35 mm	<b>9469 813 801</b>	SKF VKHB 2353

**SKF****Wheel bearing set**

Outer $\varnothing$	Inner $\varnothing$	Width	Order no	Comparative no
72/100 mm	35/55 mm	24,2/40 mm	<b>8001 526 500</b>	SKF VKBA 5265
130/120 mm	70/70 mm	43/37 mm	<b>8001 534 300</b>	SKF VKBA 5343

## Insert Unit (IU)



### Product description:

The Insert Unit is a further development of the standard tapered roller bearing. It is supplied in pairs, i.e. in each case an inner and outer bearing including two shaft seals. It can be dismantled in the same way as the standard tapered roller bearing and is neither lubricated nor sealed. The bearing must therefore be lubricated with grease suitable for the particular application before installation. The two bearings are connected with a circlip after assembly (included in the scope of delivery).

The circlip guarantees that the bearings are not damaged during mounting onto the axle shaft or that they are held in position and they do not fall apart during potential brake repair work or removal of the wheel hub.

### Note:

The wheel must be turned opposite to the direction of tightening during the adjustment process or tensioning.

### Assembly:

1. Clean wheel hub and check for oval deformation
2. Lubricate both bearing inner rings, rolling element and cage with suitable grease
3. Press the two outer bearing shells into the wheel hub
4. Insert the lubricated inner rings with rollers and cage into the wheel hub
5. Insert the circlip
6. Press on the shaft seals to seal the wheel hub using a suitable tool
7. Position the wheel hub on the axle shaft
8. Secure the axle nuts and adjust the bearings according to the manufacturer's instructions

# FAG

Wheel bearing

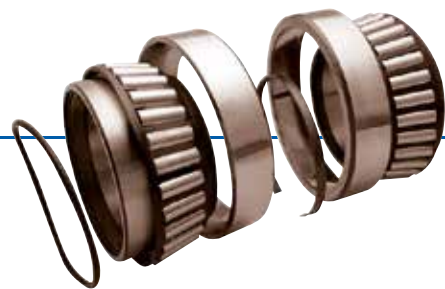

Suitable for	Outer $\varnothing$	Inner $\varnothing$	Width	Order no	Comparative no
MAN, Mercedes-Benz, Neoplan, Scania, VDL, Volvo	160 mm	105 mm	140 mm	<b>6953 426 097</b>	FAG 803750B
MAN	170 mm	110 mm	146 mm	<b>6950 020 346</b>	FAG 804162A

## Repair Insert Unit (RIU)



### Product description:

The Repair Insert Unit is a technical further development of the Insert Unit. It is a pre-assembled, sealed and lifetime-lubricated wheel bearing unit and has a factory set preload. This preload increases the rigidity and service life and reduces running noises. It consists of two tapered roller bearings which are connected by a circlip after assembly. The circlip guarantees that the bearings are not damaged during mounting onto the axle shaft or that they are held in position and they do not fall apart during potential brake repair work or removal of the wheel hub. In addition, the Repair Insert Unit is supplied with a special tool, which enables simple and convenient assembly. The advantage of this system is that it reduces the risk of using contaminated or the wrong type of grease and the time needed for assembly. Thanks to a rationalization of the part numbers there is a reduction in the cost of stock required.

### Note:

The wheel must be turned opposite to the direction of tightening during the adjustment process or tensioning.

### Assembly:

1. Clean wheel hub and check for oval deformation
2. Fit the inner and outer bearing in the hub (the bearings are labelled with "Inboard = Inside" and "Outboard = Outside")
3. Fit the circlip, ensuring it is fitted correctly. It must be possible to turn the circlip easily in its location after assembly.
4. Before fitting the wheel hub, ensure that the supplied O-ring is fitted at its position on the inner bearing. The O-ring protects against the ingress of dirt and water.
5. Position the wheel hub on the axle shaft
6. Tighten the axle nuts to the torque specified by the manufacturer



This figure corresponds to 5034 343 020



(Illustration similar)

### Repair kit for wheel bearing

SAF		FAG	
Order no	Comparative no	Order no	Comparative no
5034 343 019	SAF 3.434.3019.00	6950 530 195	FAG 570530.H195
5034 343 020	SAF 3.434.3020.00	6950 530 195	FAG 570530.H195
5034 343 021	SAF 3.434.3021.00	6950 530 195	FAG 570530.H195
5034 343 022	SAF 3.434.3022.00	6950 530 195	FAG 570530.H195

This figure corresponds to  
5034 343 020

(Illustration similar)

## Repair kit for wheel bearing

SAF ●

FAG

Order no	Comparative no	Order no	Comparative no
5034 343 011	SAF 3.434.3011.00	6950 847 195	FAG 566847.H195
5034 343 012	SAF 3.434.3012.00	6950 830 195	FAG 566830.H195
5034 343 018	SAF 3.434.3018.00	6950 868 195	FAG 569868.H195

# FAG

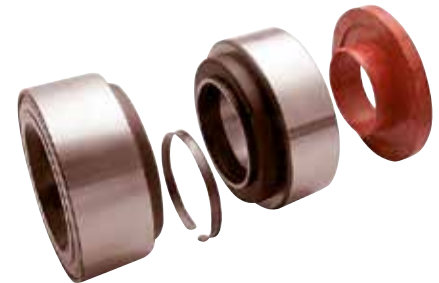

This figure corresponds to 6955 660 240

## Wheel bearing

Suitable for	Outer ∅	Inner ∅	Width	Order no	Comparative no
DAF	125 mm	70 mm	114 mm	6955 660 240	FAG 566074.H195
DAF	138 mm	82 mm	130 mm	6950 093 195	FAG 566193.H195
DAF	148 mm	100 mm	135 mm	6958 015 940	FAG 566283.H195
Renault, Volvo	148 mm	93,8 mm	135 mm	8000 566 425	FAG 566425.H195
SAF	175 mm	120 mm	123 mm	6950 830 195	FAG 566830.H195
DAF	124,7 mm	70 mm	110 mm	6955 668 195	FAG 566834.H195
SAF	148 mm	100 mm	141 mm	6950 847 195	FAG 566847.H195
SAF	138 mm	82 mm	110 mm	6950 868 195	FAG 569868.H195
SAF	138 mm	88 mm	120 mm	6950 530 195	FAG 570530.H195

# FAG



(Illustration similar)

## Compact bearing

Suitable for	Outer ∅	Inner ∅	Width	Order no	Comparative no
Renault, Volvo	125 mm	68 mm	115 mm	6956 642 673	FAG 566426.H195
Renault, Volvo	110 mm	57,8 mm	115 mm	6950 427 195	FAG 566427.H195

# FAG SmartSET

## The ready to install wheel bearing repair solution for truck, trailer and buses

The majority of wheel bearing repairs for trucks, trailers and buses are still made using conventional tapered roller bearings. This is very time-consuming, includes complicated work steps and involves many potential error sources.

Schaeffler, with its brand FAG, is an original equipment supplier to almost all truck and axle manufacturers world-wide and now offers a unique repair solution for wheel hubs in the aftermarket.

The FAG SmartSET consists of 2 pre-assembled bearing units (inboard/outboard), special tools and installation instructions for repair of a wheel bearing.

The bearing units are ready to fit, lifetime lubricated and factory pre-set. The new design means the hub can be pushed onto the axle easily – without tilting.

### Advantages:

- Quicker: workshops save up to 2 hours per axle for all brake repairs, because the units remain in the hub during removal of the brake.
- More efficient: Pre-setting of the tapered rollers and the innovative push-fit clearance enable the repair to be carried out as a one-man-job
- More practical: The ready-to-fit SmartSET with press-in tools makes work easier. The factory lubrication with special grease means there is no need for tiresome lubrication on site.
- Smarter: The SmartSET saves time and costs, and simplifies the repair work in the workshop.

The FAG SmartSET consists of 2 wheel bearing units, each with the following components:

- Outer and inner ring
- Rolling element
- Plastic cage with retaining brackets
- Support ring
- Dust protection cover

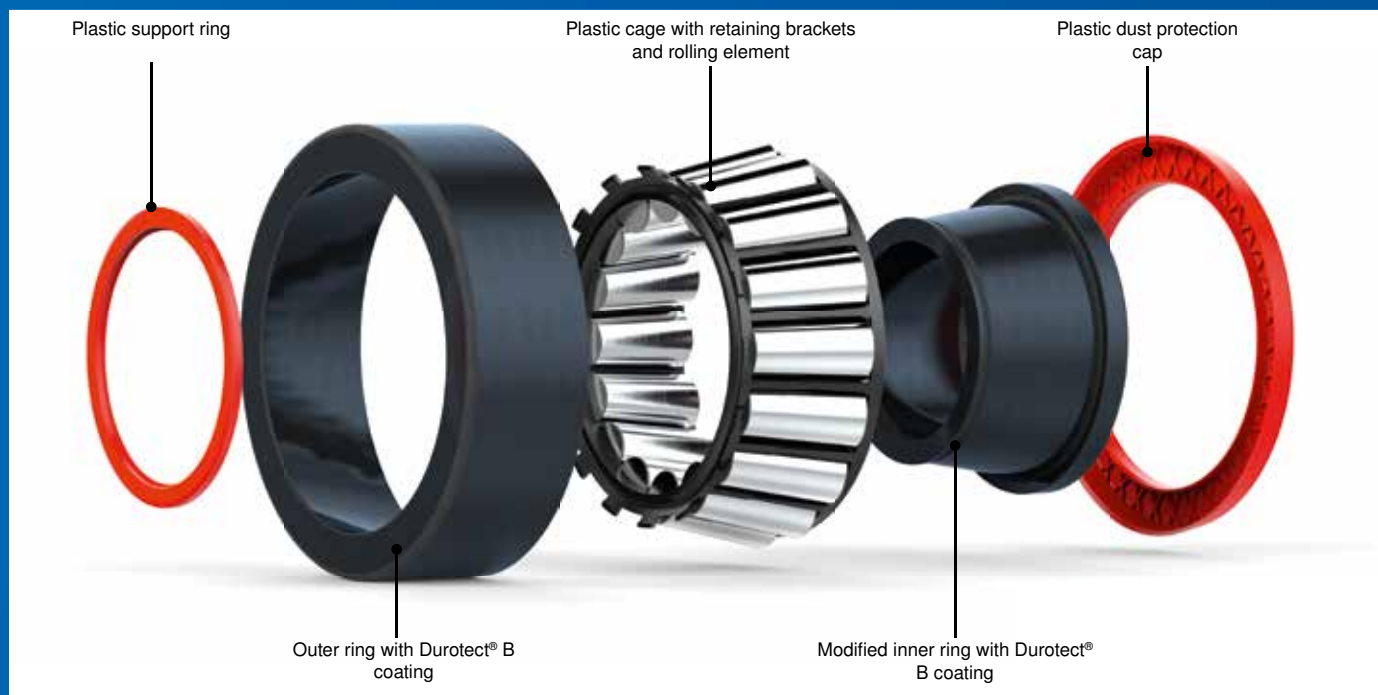

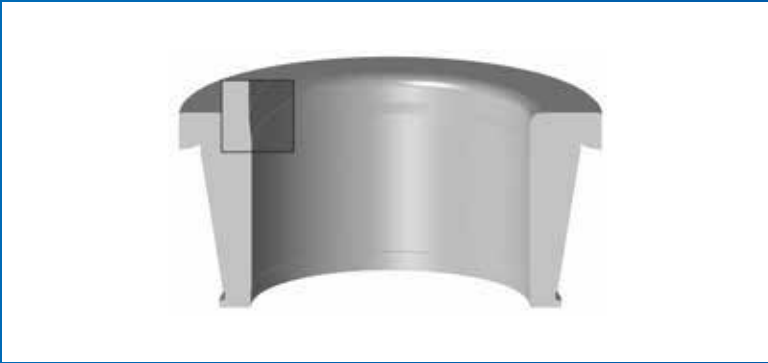

A modified inner ring makes it easier to slide the wheel hub onto the kingpin. The internal diameter has been provided with an extended conical bore, in addition to the so-called edge shortening/edge rounding. In addition, the internal diameter has a positive tolerance limit compared to a standard tapered roller bearing, which means a so-called push fit is achieved. This means the wheel hub can be moved forwards and backwards more easily on the axle stub during assembly and disassembly. Tilting of the wheel hub and thus possible tilting of the bearing on the axle stub is therefore no longer possible.

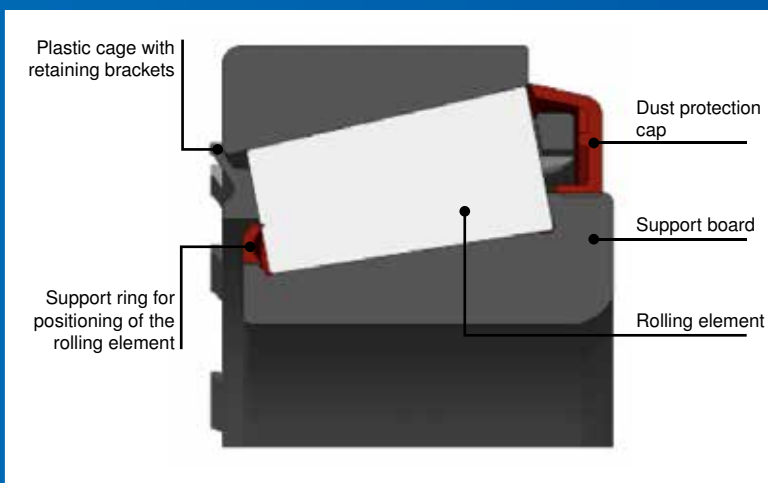

### Plastic cage and support ring

The solid, glass-fibre reinforced plastic cage with retaining brackets creates a positive-locking connection between the rolling element and the outer ring. The outer ring and inner ring are held together with the rolling element and result in one unit. This has the advantage that the bearings no longer fall apart when the wheel hub is removed, e.g. during a brake repair, and cannot be contaminated with dirt particles. An additional support ring positions the rolling element on the support panel (see image). Thanks to this so-called pre-positioning/pre-adjustment of the rolling element, the wheel no longer has to be turned during tightening of the wheel nuts. This means possible assembly errors are minimised and, in comparison to the standard tapered roller bearing, more reliable assembly can be guaranteed. In addition, the FAG SmartSET is lifetime-lubricated and is fitted with a dust protection cap, which prevents the ingress of dirt.

**Note:**

To prevent damaging the tool with the extrusion punch during pressing in, we recommend placing an additional metal plate, of corresponding size, between the tool and the extrusion punch. To ensure that the shaft seal can be guided easily over the kingpin during fitting of the complete wheel hub, the sealing lip must be lightly coated with grease. During the tightening process, it is no longer necessary to turn the wheel when using the FAG SmartSET.

**Assembly:**

1. Clean wheel hub and check for oval deformation
2. Position the outer FAG SmartSET on the hub and press into the hub using the enclosed tool – bearing is pre-lubricated
3. Position the inner FAG SmartSET on the hub and press into the hub using the enclosed tool – bearing is pre-lubricated
4. Position the shaft seal and press in with a suitable tool
5. Carefully push the wheel hub onto the axle stub and fit the thrust washer and central nut
6. Tighten the central nut according to the manufacturer's specifications

The FAG SmartSET has the following advantages over a standard tapered roller bearing:

- Pre-assembled unit
- Pre-greased – lifetime lubrication
- Pre-positioned – no rotation of the wheel during adjustment of the tilt play
- Assembly aid on inner ring due to extended conical bore
- Dust protection
- Durotect® B coating
- Push fit due to modified inner ring
- Special tool included
- Doubled service life

**EUROPART**  
GOOD TO KNOW



# FAG

## Wheel bearing set

### SmartSET

Version Pre-assembled, with permanent lubrication

**Scope of supply**  
With mounting tool

Suitable for	Order no	Comparative no
BPW, Gigant	<b>6957 237 001</b>	FAG 723 7001 10
BPW	<b>6957 237 003</b>	FAG 723 7003 10
BPW, Gigant, SAF	<b>6957 237 005</b>	FAG 723 7005 10
Mercedes-Benz	<b>6957 237 006</b>	FAG 723 7006 10
Meritor (ROR), Renault, SAF, Volvo	<b>6957 237 008</b>	FAG 723 7008 10
Meritor (ROR), Scania	<b>6957 237 009</b>	FAG 723 7009 10
DAF	<b>6957 237 012</b>	FAG 723 7012 10
MAN	<b>6957 237 013</b>	FAG 723 7013 10
Scania	<b>6957 237 014</b>	FAG 723 7014 10
MAN	<b>6957 237 019</b>	FAG 723 7019 10
Mercedes-Benz	<b>6957 237 021</b>	FAG 723 7021 10
Mercedes-Benz	<b>6957 237 024</b>	FAG 723 7024 10
Mercedes-Benz	<b>6957 237 026</b>	FAG 723 7026 10
Mercedes-Benz	<b>6957 237 027</b>	FAG 723 7027 10
Mercedes-Benz	<b>6957 237 029</b>	FAG 723 7029 10
Mercedes-Benz	<b>6957 237 031</b>	FAG 723 7031 10
Mercedes-Benz	<b>6957 237 035</b>	FAG 723 7035 10
Mercedes-Benz	<b>6957 237 036</b>	FAG 723 7036 10

## Truck Axle Module (TAM)



### Product description:

The Truck Axle Module (TAM) is based on the Insert Unit (IU) and is mounted in the hub. The TAM is also pre-greased, fitted with all seals and provided with an ABS encoder ring. Depending on the application, the hub material consists of cast iron, aluminium or ADI (austempered ductile iron). The TAM is developed in accordance with the requirements or customer specifications regarding the wheel and brake.

The Truck Axle Module is a closed, and friction-minimised bearing unit with a slot for a brake disc and wheel carrier as well as an integrated ABS encoder. It is sealed, adjustment and maintenance-free and is thus a ready-to-install wheel bearing unit.

### Note:

The wheel must be turned opposite to the direction of tightening during the adjustment process or tensioning.

### Assembly:

1. Fit the wheel carrier/brake disc on the Truck Axle Module (TAM)
2. Position the unit on the axle shaft
3. Tighten the axle nuts to the torque specified by the manufacturer



(Illustration similar)

# FAG

## Compact bearing

Outer  $\varnothing$  196 mm  
 Inner  $\varnothing$  70 mm  
 Width 139,5 mm

Suitable for	Order no	Comparative no
Iveco, MAN	6958 019 795	FAG 801974AE.H195

**FAG**

(Illustration similar)

**Wheel bearing set**

Outer  $\varnothing$  196 mm  
 Inner  $\varnothing$  82 mm  
 Width 113,8 mm

**Scope of supply**  
 Hub unit, bolts and O-ring

Suitable for	Order no	Comparative no
SAF, Schmitz Cargobull	6950 564 734	FAG 564734.H195

**SKF**

This figure corresponds to 8001 554 900

**Wheel bearing set**

Suitable for	Outer $\varnothing$	Inner $\varnothing$	Width	Order no	Comparative no
MAN, Neoplan	196 mm	70 mm	130 mm	8001 000 210	SKF VKBA 5377
Iveco, MAN	145 mm	55 mm	100,5 mm	8000 054 110	SKF VKBA 5411
SAF, Schmitz Cargobull	112 mm	82 mm	196 mm	8001 554 900	SKF VKBA 5549

**SAF****Repair kit**

Outer  $\varnothing$  112 mm  
 Inner  $\varnothing$  82 mm  
 Width 96 mm

**Scope of supply**  
 1x O-ring, 12x Torx® screws, 1x grease and 1x wheel bearings



Suitable for	Order no	Comparative no
SAF, Schmitz Cargobull	5034 343 650	SAF 3.434.3650.00

## Truck Hub Unit (THU)



### Product description:

The Truck Hub Unit (THU), unlike the standard tapered roller bearing and the Insert Unit, consists of an outer ring and two inner rings, each with a row of tapered rollers. It is supplied fully assembled or ready for installation, including seals and lifetime lubrication.

The Truck Hub Unit is a closed bearing unit with integrated shaft seals. It has a factory-set preload, is maintenance-free and is equipped with a predefined bearing clearance. This solution guarantees a longer service life. In addition, the THU allows workshops to carry out faster and easier replacements.

### Note:

The wheel must be turned opposite to the direction of tightening during the adjustment process or tensioning.

### Assembly:

1. Clean wheel hub and check for oval deformation
2. Press in the bearing unit with a suitable tool.  
Pressing into a hub must only be executed via the outer ring, as otherwise the bearing will be damaged.
3. Insert the circlip, if available. Depending on the manufacturer, the THU can be secured with an additional circlip (retaining ring).
4. Position the wheel hub on the axle shaft
5. Tighten the axle nuts to the torque specified by the manufacturer

# FAG

## Compact bearing



Suitable for	Outer $\varnothing$	Inner $\varnothing$	Width	Order no	Comparative no
Scania	127,3 mm	68 mm	115 mm	<b>6951 762 195</b>	FAG 571762.01.H195
DAF, Mercedes-Benz, Volvo	130 mm	78 mm	90 mm	<b>6959 812 205</b>	FAG 803194.26H195
Mercedes-Benz	140 mm	82 mm	115 mm	<b>9469 819 305</b>	FAG 805003A.H195
MAN	140 mm	82 mm	115 mm	<b>6958 500 395</b>	FAG 805003CA.H195
Iveco, MAN, Mercedes-Benz, Volvo	130 mm	78 mm	90 mm	<b>6958 092 017</b>	FAG 805092.07



This figure corresponds to 8001 531 400



## Wheel bearing set

### Scope of supply

compact bearing and sealing ring

Suitable for	Outer $\varnothing$	Inner $\varnothing$	Width	Order no	Comparative no
Scania	127 mm	68 mm	115 mm	<b>8001 531 400</b>	SKF VKBA 5314
DAF, Irisbus, Iveco	160 mm	90 mm	125 mm	<b>8000 539 700</b>	SKF VKBA 5397
Iveco, Volvo	140 mm	82 mm	110 mm	<b>8000 054 090</b>	SKF VKBA 5409

# FAG

# EASY TO INSTALL.



**Difficult to break.**

**FAG SmartSET — the ready-to-fit repair solution for truck wheel bearings.**

**Pre-assembled, pre-greased, pre-positioned** — the FAG SmartSET was developed exclusively for the spare parts market, based on the needs of the garage. The new repair solution for truck and trailer minimizes downtime for repairs and maximizes service life.

**Further information:**

[www.schaeffler-aftermarket.com](http://www.schaeffler-aftermarket.com)

[www.repxpert.com](http://www.repxpert.com)



## SCHAEFFLER

## Tools/Workshop requirements



PREMIUM-WERKZEUGE  
**KSTOOLS**  
 PREMIUM TOOLS

### Universal hub removal kit

Hole circle  $\varnothing$  110-448 mm  
 Suitable for Bolt diameter up to max. 30 mm  
 Material Special steel

**Application range**  
 BPW, SAF, Scania, Fuso, Hino, etc.

**Scope of supply**  
 – with 2 tension rods and trapezoidal thread spindle  
 – with 3 pressure pieces  
 – including 6 thread adapter sets

Order no

9504 601 765



**GEDORE**  
 WERKZEUGE FÜR'S LEBEN  
 formerly **KLANN**

### Hub removal kit

Enables proper removal of the wheel hub from the drive axle. The wheel hub is removed via the wheel bolts, the different pressure pieces enable central support via the axle tube. Thanks to the 28 t hydraulic cylinder in connection with the hand pump, even firmly fixed wheel hubs can be removed easily.

Basic frame load, max. 28 t  
 Pressure spindle load, max. 28 t

**Application range**  
 NKW wheel hubs (as well as wheel hubs with integrated compact wheel bearing) with removable hub cap, for axle systems with a bolt circle diameter of 8 x 275 and 10 x 335 on ZF, BPW and SAF front or rear axles, installed e.g. on Mercedes-Benz Actros rear axle, Citaro ZF rear axle, MAN TGA rear axle, Renault, Volvo, Iveco, Scania, DAF, etc.

Order no

9562 100 510

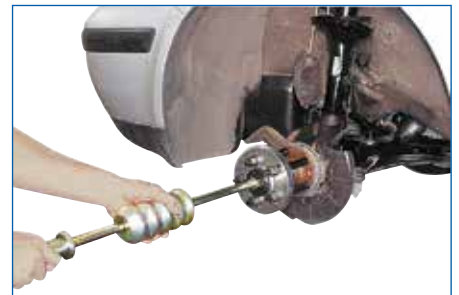
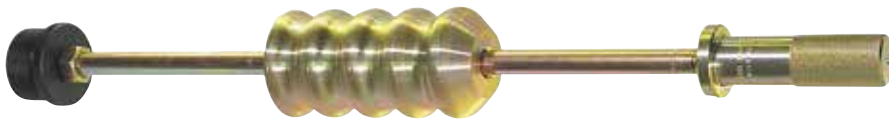

**GEDORE**  
 WERKZEUGE FÜR'S LEBEN  
 formerly **KLANN**

### Hammer puller

for pulling off wheel hubs, quick-release axles, universal joint shafts and brake drums, etc. in connection with the pulling-off device series KL-0174-...

Slide hammer 4,8 kg  
 Length 690 mm

Connection thread on the connecting rod M18

**Scope of supply**  
 With adapter 2 1/4"-14 UNS on M18

Order no

9557 050 071

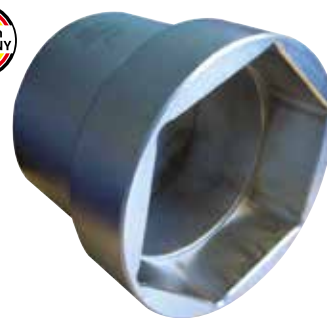

## Axle nut key

for the clean and straightforward loosening and tightening of wheel hubs and axle nuts

Suitable for	Version	Spanner size	Drive	Order no
Iveco EuroCargo and Volvo F10	Hexagon	65 mm	1"	9005 342 939
Scania	Hexagon	70 mm	1"	9005 342 928
Scania, BPW and SAF	Hexagon	85 mm	1"	2300 041 003
Fiat and Iveco EuroCargo 4 x 4	Hexagon	90 mm	1"	9512 350 000
Volvo F7, F12 and Fiat 309	Hexagon	95 mm	1"	9005 342 938
Volvo FL7, FL10, F12, F16, Fiat 309 and DAF 1700	Hexagon	105 mm	1"	9005 342 937
Fiat and Fruehauf	Hexagon	110 mm	1"	9005 342 936
Ford Transcontinental and DAF	Hexagon	115 mm	1"	9005 342 925
Scania and DAF	Hexagon	120 mm	1"	9005 342 131
Scania front axle	octagonal	80 mm	1"	9005 342 129
BPW	octagonal	95 mm	1"	8000 003 596
Scania rear axle	octagonal	100 mm	1"	9005 342 934
Scania	octagonal	102 mm	1"	9005 342 946
BPW	octagonal	110 mm	1"	9005 342 935
	octagonal	115 mm	1"	9005 342 061
	octagonal	120 mm	1"	9005 341 607
BPW	oval	65 mm	3/4"	9005 342 945
BPW	oval	80 mm	3/4"	9005 342 926
BPW	oval	95 mm	3/4"	9005 342 932
BPW	oval	110 mm	3/4"	8000 003 724

## EUROPART® – a strong brand name

In addition to well-known manufacturers' branded products, EUROPART also offers a comprehensive Premium Parts Programme with 7,000 articles from the different EUROPART product ranges.

### Your advantages:

- Highest quality standards
- Maximum availability at 300 locations in 28 countries
- Increasing your competitiveness
- Consistent service package



**EUROPART**  
GOOD TO KNOW



### Axle nut key

for loosening and tightening of square self-locking nuts on axles

Suitable for	Size	Drive	Order no
DAF, Mercedes-Benz axles VL 3/8, 4/7, 4/9, 4/15, and VD 4/14 in types 363, 385, 387, 839, 391, 393, 395, 617, 620, 621, 622, 623, 625 and 649 (e.g. Mercedes-Benz Actros with drum brake self-locking nut no. 652 330 00 88), Mercedes-Benz bus axles VO 3/10, 4/11, 4/13 and 4/19 in types 0303, 0305-G and 0307, MAN axles (with self-locking nut no. 81.92901-0066), Kässbohrer/Setra axles: front axle 6,5 and 7,5 t in types S 210 and 215, SG 219-221 and trailing axles types S 216 HDS and S 228 DT	56 x 71 mm	3/4"	9500 155 720
Mercedes-Benz SK front axles VL 5/1D-9, VL5/2-D in types 2629/6 x 4, 2635K/6 x 4, 3535K/8 x 4/, e.g. Actros with disc brake self-locking nut no. 6563300088, as well as Faust front axle 9	60 x 76 mm		9500 155 719
Mercedes-Benz axle VL 2/7-8 in pattern 380, types 1013 S-K and 1017 S-K	41 x 50 mm	1/2"	9557 050 060
MAN/VW G-series, axle V 7 - 26L - 36L, types 8.136 and 8.150	46 x 52 mm	1/2"	9557 050 061
Mercedes-Benz axle VL 2/11 in type 814 (light-weight construction series)	50 x 62 mm	1/2"	9557 050 062
Mercedes-Benz, Setra S 215 HDH (1990-) and Neoplan (1990-)	54 x 68 mm	3/4"	9557 050 063



### Axle nut key

for the clean and simple loosening and tightening of flat-oval wheel hubs and axle nuts, e.g. on BPW axles

Drive 3/4"

Spanner size	Order no
65 mm	9501 200 065
80 mm	9501 200 080
85 mm	9501 200 085
95 mm	9501 200 095
120 mm	9501 200 120
110 mm	9557 050 064



### Nut and cap wrench set

for assembly and disassembly of various nuts, more exact torque-tightening possible using 3/4" square drive, safe grip with tension screws and adapter guide on the base unit, narrow design, can be used in tight spaces, ideal for use with special nuts and caps

Torque, max. 700 Nm  
 Material Special steel  
 Groove or hole spacing, a max. 145 mm  
**Application range**  
 hexagonal, octagonal, groove and round nuts

Version	Order no
13-piece	9569 740 180

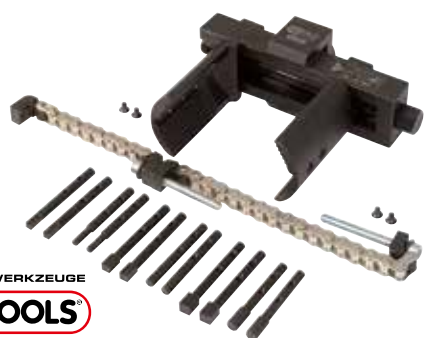

PREMIUM-WERKZEUGE  
**KS TOOLS**  
PREMIUM TOOLS

## Nut and cap wrench set

Extra heavy design, for assembly and disassembly of Vario nuts, more exact torque-tightening possible using 3/4" square drive, safe grip with tension screws and adapter guide on the base unit, narrow design, can be used in tight spaces, ideal for use with special nuts and caps

Material Special steel

Groove or hole spacing, a max. 145 mm

### Application range

Hexagonal, octagonal, grooved and round nuts

### Scope of supply

Tension chain, round adapter, square adapter, Vario nuts cap wrench

Version	Order no
14-piece	9514 500 190

**GEDORE**  
WERKZEUGE FÜR'S LEBEN  
formerly **KLANN**

## Pin wrench

Base body and guide tubes can be combined (note connection thread), high time and cost saving, can be used universally

Version 6 journals

∅ 63 mm

### Application range

for loosening and tightening the mounting nuts e.g. on the front or rear axle and on the gearbox or differential flange

Suitable for	Scope of supply	Order no
e.g. Mercedes-Benz Hypoid rear axles: HL0/3, HL0/6, HL0/7, HL1/2 (only diameter 63 mm necessary), HL1/3, HL1/8, HL1/9, HL2/30C	with guide tube	9557 050 051
e.g. Mercedes-Benz Hypoid rear axles: HL2/2, HL2/3, HL2/5, HL2/9, HL2/11, HL2/12, HL2/15	with 3 guide tubes	9557 050 052



PREMIUM-WERKZEUGE  
**KS TOOLS**  
PREMIUM TOOLS

## Assembly/disassembly tool set

for bend-free and damage-free assembly and disassembly of bearing shells, optimal positioning by spreading the jaws, actuation either manually with hammer or with a workshop press, robust, forged design

Material Special steel

### Application range

Trucks, agricultural technology and construction machinery

### Scope of supply

with a sturdy plastic case

Version	Order no
5-piece	9504 500 080

PREMIUM-WERKZEUGE  
**KS TOOLS**  
PREMIUM TOOLS

## Bearing/bush driver set

Universally usable range, actuation either manually with a hammer or with a workshop press, retaining adapter suitable for two pressure plates

Working range 18-65 mm

Torque, max. 550 Nm

Material Special steel

### Scope of supply

Retaining adapter 45 mm, knurled driving out mandrel 220 mm, pressure plates 18-65 mm, support plates 75 mm, sturdy plastic case

Version	Order no
51-piece	9507 001 350





### Grease cap pliers

for the simple and straightforward removal of inserted grease caps

Grease cap  $\varnothing$  40-90 mm  
Length 493 mm

Order no  
**9557 050 070**



### Magnet wheel inserter

**Application range**  
For correct assembly of the shaft seal with exciter wheel

Suitable for	$\varnothing$	Order no
Mercedes-Benz Actros and Atego, e.g. cassette sealing ring in the wheel hub	150 mm	<b>9500 470 109</b>
Mercedes-Benz Actros and Atego axle or wheel hub, e.g. shaft seal with exciter wheel (Mercedes-Benz 942 334 01 15)	160 mm	<b>9500 470 110</b>
Mercedes-Benz Actros and Atego axle or wheel hub, e.g. shaft seal with exciter wheel (Mercedes-Benz 020 997 05 47)	180 mm	<b>9557 050 058</b>

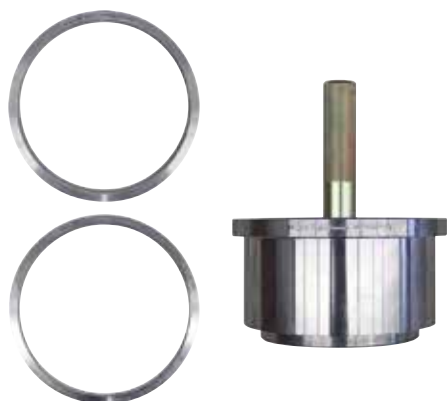

### Magnet wheel inserter

$\varnothing$  175 mm

Suitable for	Order no
Mercedes Actros and Atego rear axle shaft seals (e.g. Actros rear axle MB no. - 746.217_O / - 770.001_F / - 771.0_F / - 771.1_F / - 740.8_S / - 746.210_S / - 748.2_S / - 748.7_S / - 746.213_S / - 741.71_S / - 746.21_S / - 746.301_S / - 748.59_S and Atego 9 t rear axle MB no. - 770.003_F, - 770.002_F, - 770.000_F.)	<b>9557 050 059</b>

**Application range**  
For correct assembly of the shaft seal with exciter wheel

**Scope of supply**  
Shaft seal pressing in tool diameter 175 mm, ring 7.5 mm (KL-1025-1752 A), ring 17.5 mm (KL-1025-1753 A)

**Rings KL-1025-1752 A and KL-1025-1753 A are required for the rear axle series 746.21 and 748.59 with double seal.**



### Tool case

Type ZB9036

**Application range**  
Disc brake

**Scope of supply**  
Pulling fork for pressure piece with bellows (I132202)  
Puller for inner bellows, guide sleeve (Z004357)  
Puller/extractor with caulking device for brass bushing (calliper bearing) (Z004354)  
Press-in tool for cover (K017062)  
Press-in tool for cap (Z003934)  
Press-in tool for inner seal (Z004361)  
Puller/extractor for guide sleeve (Z004198)

Order no	Comparative no
<b>3400 597 200</b>	Knorr K039062K50



### Test gauge for brake cylinder

Tests the interface between brake and brake cylinder, such as whether the plunger dimension (15 mm), seal protrusion (>3 mm) and the position of the clamping sleeve are correct, supports the maintenance process and decision making during servicing, reduces downtimes, helps during use of the service kit

Order no	3400 036 100
----------	--------------



### Brake spring pliers for drum brakes

with special binding and supporting crown, especially suitable for glued brake pads, heavy-duty model with exchangeable spring hooks and hand pinch protection

Length 500 mm  
Material Chrome vanadium steel  
Surface chrome-plated

Order no	9240 072 390
----------	--------------



### Circlip pliers set

with ratchet function  
**Application range**  
Internal rings 78-159 mm  
External rings 89-159 mm

Version	Order no
14-piece	8000 001 300



### Circlip pliers set

with ratchet function, self-opening, replaceable tips, 8 different jaws for selection through reconnection, with disassembly and assembly aid, rubber handle

Material Chrome vanadium

**Application range**  
Internal circlips 60-100 mm  
External circlips 40-85 mm

Version	Order no
20-piece	9505 001 350



### Assortment case Circlip DIN 471 (outside)

Version 18-compartment

**Scope of supply**  
180 pieces, assorted  
blank, dimensions: 8 x 0.8 to 34 x 1.5



Order no	9500 449 182
----------	--------------



**Assortment case  
Circlip DIN 472 (inside)**

Version 18-compartment

**Scope of supply**

180 pieces, assorted  
blank, dimensions: 15 x 1 to 38 x 1.5

<b>Order no</b>
<b>9500 449 183</b>



**Impact Air Wrench**

high-performance double impact striking device, cold insulated, low vibration, comfort handle, exhaust air guided through handle, multi-stage adjustable torque with clockwise rotation, reversible right/left direction of rotation with single-hand control, can be used with screws up to size M16

Model	Torque, max.	Speed, maximum	Air consumption	Order no
EP-Duo 1/2"	950 Nm	8500 min <sup>-1</sup>	133 l/min	<b>9564 290 001</b>
EP-Duo 3/4"	1630 Nm	5750 min <sup>-1</sup>	195 l/min	<b>9565 290 002</b>



**Impact Air Wrench  
5120XP-6EP**

High performance double hammer impact mechanism, 3-level power control, including connector plug with composite housing

Drive	1"
Torque	1800 Nm
Speed	5000 min <sup>-1</sup>
Air consumption	410 l/min
Hose inner-Ø	14 mm

<b>Order no</b>
<b>9564 295 120</b>



**Torque multiplier**

Translation 1:58

**Scope of supply**

1 each bit 32 and 33 mm, 1 extension, in case

**Only to be used for undoing! The extreme ratio can otherwise cause damage.**

<b>Order no</b>
<b>3002 413 237</b>



### Torque wrench

adjustable, with square drive and integrated ratchet function for controlled right/left tightening, square section insert with pin lock, bending mechanism with castor guarantees a tactile and audible triggering signal, additional micrometer scale, dual scale Nm and lbf/ft under a viewing window with magnifying effect, with test certificate according to DIN EN ISO 6789:2003, traceable back to national measurement standards

Drive 3/4"  
Working range 250-850 Nm  
Scale division 1 Nm

triggering accuracy +/- 3% of the set value  
controlled screw tightening in the case of commercial vehicles in the common range of 250-850 Nm

Order no

9856 860 300



### Torque wrench

adjustable, with square drive and integrated ratchet function for controlled right- and left-handed thread tightening, 1/2" mushroom-headed changeover square with ball-latching, additional micrometer scale, with test certificate to DIN EN ISO 6789

Drive 1/2"  
Working range 20-200 Nm, 15-150 lbf/ft  
Scale division 1 Nm

Triggering accuracy +/- 3% of the set value

Order no

9856 860 200



### Spider wrench for trucks

Spanner size 24 x 27 x 30 x 32 mm + 13/16"  
(AF 15/16 x 1 1/16 x 1 3/16 x 1 1/4 + 13/16)  
Dimensions 750 x 750 mm  
Material Chrome-vanadium steel

Order no

9524 270 507



### Rim remover

Special lever for removal of commercial vehicle rims that have rusted onto the hub, no damage to the rim, with adjustable pull-off hook for various rim types, high force applied due to 1600 mm-long lever

Overall length 1700 mm  
Overall width 130 mm  
Overall height 110 mm

Order no

9500 992 301





## Wheel jacking press

for loosening or forcing off wheels or rims that are stuck

Max. load of the hydraulic cylinder: 10 t

Connection thread for hydraulic coupling: 3/8" NPT

### Application range

Can be used universally for commercial vehicle wheels that are stuck (single and twin tyres)

### Scope of supply

- Hydraulic cylinder
- Coupling halves 1/4" NPT (cylinder-side)
- Adapter 3/8" NPT to 1/4" NPT
- Support plate
- Pressure piece 1 (25 mm long)
- Pressure piece 2 (50 mm long)
- Pressure piece 3 (75 mm long)

**Wheel forcing press must only be used with a hydraulic hand pump!**



Order no

9501 557 075



## Wheel mounter

roll, turn, lift and lower, guarantees easy transportation, easy removal and refitting of truck tyres, one man operation, 3 settings for the rollers depending on the tyre size, superb tool for the service cart, easy to remove lever, prevents damage at the wheel studs and expensive modern rims, now with extended rollers - ideal for wide tyres

Load capacity max. 250 kg  
 Suitable for Wheel sizes from 6.5" to 22.5"  
 Weight 11,2 kg

Order no

9530 471 105



## Wheel mounting device

### WTA 500, hydraulic

for fast and ergonomic wheel changing, large lifting height enables loading and unloading of transport vehicles, laterally adjustable lifting arm for wheel diameters 270-1300 mm, lifting arm with roller bearing for easy adjustment of the wheel, foot-operated pump, safety bar for fast mounting of the wheel during transport, 2 wheels can be swivelled by 360°

Order no

5322 520 012

### Accessories

#### Description

Installation crane

Order no

5322 520 013



## Centring sleeve

For assembly of the compact wheel bearing with wheel hub, to slide this onto the axle tube precisely and without tilting



Suitable for	Connection thread	Outer $\varnothing$	Length	Spanner size	Order no
MAN rear axle HY-0925-00 e.g. on TGL, TGM	M75 x 1.5	82 mm	197 mm	41 mm	9557 050 056
MAN rear axle HY 1350 e.g. on TGA, TGX, etc.	M100 x 1.5	105 mm	360 mm		9501 027 100
Mercedes-Benz front axle 730.714 F, 730.715 F, 730.719 F, 730.720 S, 730.026, 730.027, 730.028 e.g. on Atego, etc.	M45 x 1.5	60 mm	145 mm	41 mm	9557 050 053
Mercedes-Benz rear axle HL 2/43 specimen 742.503 / 504 / 505 / 506 / 509 e.g. o Atego I/II, Tourino	M75 x 1.5	78 mm	186 mm	41 mm	9557 050 057
SAF axles with right or left-hand thread	M75 x 1.5	82 mm	150 mm		9557 050 054
SAF axles with right or left-hand thread	M75 x 1.5	88 mm	150 mm		9557 050 055



## Centring sleeves set

for the simple and straightforward fitting of truck wheels, the centring sleeves are screwed on and off using a standard 1/2" reversible ratchet, saving lots of time, preventing damage to the thread, exact centring thanks to the conical sleeve shape

$\varnothing$ of rim hole	Threaded bolt	Order no
24 mm	M18 x 1,5	9500 601 824
26 mm	M22 x 1,5	9500 602 226
32 mm	M22 x 1,5	9500 602 232



## Wheel nut wrench for trucks

Length 400 mm  
Version forged  
Material Special steel  
Surface silver painted

Spanner size	Order no
24 x 27 mm	9534 005 070
30 x 32 mm	9534 005 065
30 x 33 mm	9534 005 055
32 x 33 mm	9500 498 010



## Torque limiter

### AccuTorq

The torque limiter works in that superfluous impact screwdriver blows are absorbed through the torsion bar between the drive and the hexagon end after the right torque has been reached.

These wrenches are calibrated in production, so that no further calibration is necessary. The service life can only be reduced by worn impact screwdriver anvils or wheel bolts. Torque limiters do not transfer more torque than that specified on the respective wrench. For this reason, the only precision test required is to check whether sufficient force is available to achieve the right values with the respective wrench.

Length 305 mm

#### Advantages

- combines the speed of impact screwdrivers with the precision of torque wrenches
- suitable for all 1" impact screwdrivers with at least 1400 Nm
- no further settings are required

Spanner size	Torque	Order no
32 mm	600 Nm	9501 557 026
33 mm	650 Nm	9501 557 030



## Axle leg bolt press set

### FP 73

for pressing bolts in and out without removing the front axle, saves a great deal of time, easy to handle, works in any position, high pressing force, can also be used as a stationary and mobile workshop press

- Pressure 73 t
- Stroke 115 mm
- Clearance 250 mm
- Piston Ø 65 mm
- Traverse bore 70 mm
- Version for MAN special application as well as all other trucks



#### Scope of supply

- 1 press body, 2 stay bolts, 1 transverse bridge complete, 1 reducer for bridge bore (diameter 70/55 mm),
- 1 separate hand pump with 1.8 m hydraulic hose, 1 pressure bolt set (8-piece, diameter 21.5 - 39 mm),
- 1 bridge and piston locking piece, 1 lifting and moving cart (pivoted)

Order no

9534 004 055

#### Accessories

1



2



3



#### Description

Fig. Order no

MAN Special accessories, piston bore (35/25 mm diameter), bridge reduction (70/65 mm diameter), 2-piece	1	9534 004 056
Mercedes-Benz bus Special accessories, BR 1, BR 2, BR 3 (38 mm diameter), BR 3 (45 mm diameter), BR 4 (bushing), BR 4 (needle bearing), BR 1-LN 1, V 04, VL 5, Ø 45 mm x Length 245/120 mm, 11-piece	2	9534 004 066
Foot pump, pneumatic-hydraulic, Rate of delivery 0.5 l/min, Pressure, max. 700 bar	3	9534 004 090



## Oil pan

specially shaped for use in the rim well, collects the oil when the hub cover is undone or removed, prevents loss of oil during axle repair or checking, deeper rim prevents overflow spillage, spout opening for easy emptying

Suitable for rim size from 35 cm (13-3/4") inner diameter

Collection volume 3 l

Material PP (polypropylene)

### Application range

specially for rear axle hubs on trucks



Order no

9539 641 192



## Jack

### air-hydraulic

EUROPART own-brand car jacks are manufactured from special materials which guarantee their function, quality and breaking strength, even in the most extreme situations.

Pressure range 8-10 bar

### Scope of supply

2 adapters, 60 mm

Model	Load capacity	Lifting height	Weight	Order no
EP 214 mobil	20/10 t	140-306 mm	15 kg	9539 650 200
EP 215 N	40/20 t	150-300 mm	39 kg	9539 650 201
EP 222 N	60/30 t	220-450 mm	71 kg	9539 650 202
EP 312	60/30/15 t	120-255 mm	50 kg	9539 650 203
EP 330 N	80/50/25 t	310-824 mm	103 kg	9539 650 204

\* portable

### Accessories

Description	Fig.	Order no
Saddle, Load capacity 80 t	1	9539 650 205
V fifth wheel, Load capacity 80 t	2	9539 650 206



## Workshop-pit lifters

### air-hydraulic

rapid and precise air hydraulics with fast up and down travel, with operating panel at the ergonomically correct working height, maintenance unit as standard, laterally moveable lift cylinder with spring-mounted ball bearings

Piston stroke 800 mm  
 Height, max. 1820 mm  
 Height, min. 1020 mm  
 Cylinder-∅ 60 mm

**Scope of supply**  
 with suspension

**Many modern vehicles must today be raised at 2 points. Check the use of axle traverses!**



Model	Load capacity	Order no
GD 100-1	10 t	5322 520 135
GD 150-1	15 t	5322 520 136
GD 200-1	20 t	5322 520 137



## Axle traverse

### T5-1

For secure two-point attachment on the axle or if cannot be lifted by the differential. Measured from the central carrying plate, a load capacity of **15 t** is achieved with an extension length of 1400 mm and **11.5 t** at the maximum extension of 1500 mm. New: 2 cross beams in one! Virtually all vehicles can be easily lifted with this axle traverse

Load capacity 15/11,5 t  
 Seat-∅ 60 mm

**Please quote the make of the pit lift and the fitting diameter. Adaptation to different fitting diameters is available on request.**

Order no
5322 520 149



#### Accessories

Description	Fig.	Order no
V fifth wheel, Width 100 mm	1	5322 520 141
U fifth wheel, Width 100 mm	2	5322 520 142
Extension, raises the lifting height by 100 mm	3	5322 520 143
Extension, raises the lifting height by 200 mm	4	5322 520 144
Adapter, Blitz 55 mm on AC 60 mm, both sides male half		5322 520 147
Adapter, Slift 45 mm on AC 60 mm, both sides male half		5322 520 148
Adapter, Blind hole, ∅ 35 mm		5322 520 160



## Axle traverse

### T4-1

According to the manufacturer, the current Actros series (market introduction autumn 2011) as well as the previous models can only be lifted at two points. This applies to both the rear and the front axle. Only during on the spot breakdown repairs, such as on the motorway, may the vehicles be raised selectively at the specified location point using a trolley jack. The truck axle crossbeam load plates can be adjusted in width and matched up to any load location point.

Load capacity 15 t  
 Adjustment range 125-750 mm  
 Seat-Ø 60 mm

Please quote the make of the pit lift and the diameter of the adapter when ordering. Adaptation with different adapter diameters is available on request.

Order no

5322 520 139



**GLORIA®**  
 Geräte für Haus und Garten

## Pump sprayer

### CleanMaster EXTREME EX 100

Robust precision pump, made of highly resistant polyethylene plastic and seals made of resistant Viton®, long life thank to internally curved, even floor, fill level inspection through transparent viewing strip

Container volume 1000 ml  
 Version oil-resistant  
 Colour transparent

#### Application range

Output of solvent-containing media such as brake or rim cleaners as well as tar and stain remover

Order no

9539 850 007



### Rust Remover

loosens rusty screws, nuts and machine parts, prevents new rust forming and protects parts from wear, on MoS<sub>2</sub> basis

Temperature resistance -30 to +50 °C

**Application range**

high flow properties, best rust loosening capacity, e.g. for screws, bolts, chain links, joints, levers, springs, hinges or locks, also suitable for cylinder locks

Contents	Container	Order no
400 ml	Spray can	9230 000 125



### Creeping oil spray

the oil has great penetration properties, high lubricating ability and payload, for loosening rust, lubricating inner bearings on chains, excellent lubricating properties for direct metal-to-metal contact, low running noise, low wear, lubricates inner bearings, prevents corrosion, gentle care for all moving parts

Version colourless, tasteless, odourless, does not contain acids and is free of petroleum

Temperature resistance up to +150 °C

Contents	Container	Order no
400 ml	Spray can	9230 000 115



### Delicate care spray

**Multi-7, with 7-fold effect**

infiltrates and dispels humidity, prevents voltage loss and creepage currents, penetrates gaps and capillary cavities, cleans stubborn dirt and loosens rust, protects metallic surfaces from wear and corrosion, offers an excellent gliding effect, eliminates squeaking and creaking

Packaging unit 12

Temperature resistance -30 to +60 °C

**Application range**

for industry and automotive use

Contents	Container	Order no
400 ml	Spray can	9230 000 110





### Brake cleaner

cleaning agent for universal use, thanks to special solvent it degreases, removes stubborn soiling thoroughly and gently, dries off quickly

#### Application range

cleaning of drum and disc brakes, brake blocks, springs, cheeks, clutches, pads, pressure pads and clutch parts in general, gears, carburettors, petrol pumps, engine parts etc.

Contents	Container	Order no
500 ml	Spray can	9230 000 140



### Brake cleaner

cleaning agent for universal use, thanks to special solvent it degreases, removes stubborn soiling thoroughly and gently, dries off quickly

#### Application range

cleaning of drum and disc brakes, brake pads, springs, shoes, clutches, linings, pressure plates and clutch parts in general, gears, carburettors, petrol pumps, engine parts etc.

Contents	Container	Order no
5 l	Canister	9785 000 025
10 l	Canister	9785 000 026
20 l	Canister	9785 000 027
60 l	Drum	9785 000 028



**Identify the product  
you need.  
Order at anytime.**

The EUROPART Workshop Online System: Browse, find and order the products you need 24 hours a day

## Lubrication

### Why is a lubricant required?

For roller bearings, lubrication has the primary task of minimising friction and wear by preventing or reducing metallic contact between the rolling and sliding surfaces.

Grease lubrication is used for approximately 90% of roller bearings. The current requirements for truck wheel bearings and the peak temperatures that occur there during braking of 200°C and beyond, make the use of approved lubricants an absolute requirement.

#### The main advantages of suitable grease lubrication are:

- high usage period with maintenance-free lubrication
- good support of the grease seal
- dissipation of heat
- corrosion protection of the bearing
- minimal engineering effort
- damping of running noises

### Composition of and differences between greases

Different roller bearing types have different requirements of the lubricant and its additives.

The performance of greases of the same type can vary significantly!

Lubricating greases are distinguished above all by their main components of thickener and base oil. Normal metal soaps are usually used as the thickener, but complex soaps as well as bentonite, polyurea, FEP (perfluor/plastic), PTFE (polytetrafluorethylene/plastic: Teflon, Turcon) can also be used. Mineral or synthetic oils are used as the base oil.

The viscosity of the base oil, together with the thickener share, determines the consistency of the lubricating grease and the structure of the lubricating film. Additives are also added to lubricating greases to improve the chemical or physical properties, such as corrosion protection and oxidation stability.



## Requirements of wheel bearing greases

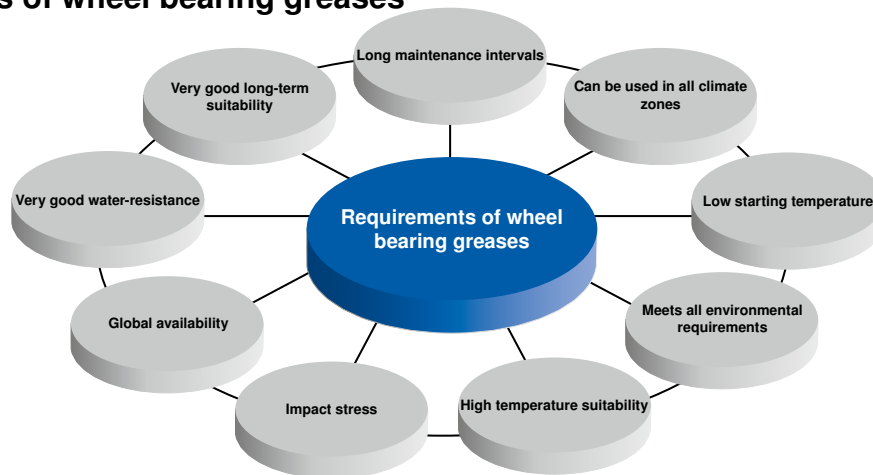

Roller bearing special greases seem to cost slightly more at first glance. However, if you want to meet the high requirements of roller bearings, you should not do without special greases.

**Arcanol Load 150 from FAG, Shell Retinax LX II and Renolit LX-NHU 2** are particularly recommended for use in wheel bearings under high temperature conditions, as occur in modern commercial vehicles. These are lithium complex greases, which are designed for a temperature range of  $-30^{\circ}\text{C}$  to  $160^{\circ}\text{C}$  with short-term peak temperatures of up to  $200^{\circ}\text{C}$ . By using special high-pressure additives, the requirements of a KP grease are met (KP grease = designation in accordance with DIN 51502). The high mechanical stability in connection with low oil separation enable use at highly stressed lubrication points.

## How do I grease wheel bearings?

Standard tapered roller bearings and Insert Units must be filled with grease before installation. It is not only the quantity that is important, but also the correct procedure when greasing a wheel bearing.

The grease must be pushed through fully from one side of the bearing to the other side, all around (see images). Then the excess grease is removed and the outside of the bearing is coated with a thin film of grease.

### Note:

To prevent damage, the prescribed grease quantity (see manufacturer's specifications) must be found in the wheel hub after assembly. If there is too little grease, the wheel bearings may run too hot. If there is too much grease, the excess grease may leak out of the wheel hub and get onto the brake pads.



**EUROPART**  
GOOD TO KNOW

## Incorrect lubrication and its causes

Over 50% of all roller bearing damage is due to faulty lubrication (see diagram). Not only is the bearing service life impaired, but damage is also caused in other components, which at first glance is not directly attributable to a lubrication fault. Unsuitable or contaminated lubricant as well as the wrong grease quantity can cause premature failure of the wheel bearing. Inadequate lubrication at the contact points can lead to fatigue damage

or even bearing hot boxes. This results in increased wear and thus premature failure of the wheel bearing.

### Overview of the possible causes of failure of a roller bearing

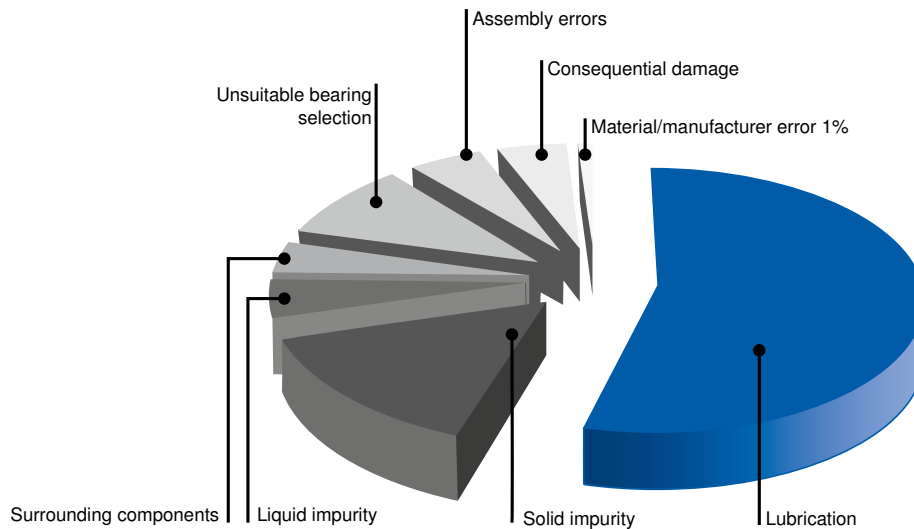

## Impacts and consequences of solid and liquid impurities:

### Solid impurities:

Solid impurities in the lubricant cause wear and premature fatigue of wheel bearings. The harder the foreign particle being rolled over, and the smaller the bearing, the quicker the service life will be reduced.

Solid impurities cause frictional wear in roller bearings, in particular at places with a high proportion of sliding motion. This occurs, for example, in the contact area of the front of the roller in the case of tapered roller bearings.

The wear increases with the hardness and size of the foreign bodies. It also increases approximately proportionally to the concentration of foreign materials in the lubricant.

Premature failure can be prevented by:

- Clean lubricants
- Effective seals
- Thorough cleaning of the parts surrounding the bearing
- Cleanliness during assembly

### Liquid impurities:

The damaging effect of liquid impurities in the lubrication is often highly underestimated. Even pure water, without additional aggressive components, has a very high damage potential in roller bearings.

The damage potential is split into the following categories:

- Reduction of the fatigue life
- Cause of wear
- Acceleration of lubricant ageing and residue formation
- Corrosion

The damage characteristics occur individually or in combination and are dependent on the type of lubricant, the bearing material and the free water quantity introduced into the lubricant. They can lead to functional failure or can completely destroy the bearing.

The choice of the correct lubricant and proper lubrication is thus crucial for a reliable service life of every bearing. To ensure that a load-bearing lubrication film can form in the contact surfaces between the rolling element and the tracks, the lubricant must be sufficiently viscous. The viscosity of a lubricant falls as temperature rises. It is therefore important to have the required viscosity at operating temperature.

**EUROPART**  
GOOD TO KNOW

## Storage conditions of wheel bearing greases

The basic requirement for storage is a closed storage room which is not exposed to any aggressive substances, such as exhaust fumes from vehicles. Direct sunlight should also be avoided.

The storage temperature should be as constant as possible and the humidity as low as possible. Temperature jumps and increased humidity lead to the formation of condensation.

### The following conditions must be observed:

- Frost-free storage at a minimum temperature of +5 °C (reliable avoidance of frost production, up to 12 hours a day at +2 °C permitted)
- Maximum temperature +40 °C
- Relative humidity less than 65% (with temperature changes maximum of up to 12 hours a day up to 70% permitted).

**EUROPART**  
**GOOD TO KNOW**



### Permanent grease

#### universal

shear-stable lithium-complex based grease, water resistant, corrosion and oxidation resistant, offers very good protection against wear, with high pressure-absorption capacity

#### Application range

for the lubrication of rolling contact bearings and plain bearings, on generators, electric motors, fans etc., also used in wheel hubs and clutch release bearings

**designation according to DIN 51 825: KP 2 N-30**

**designation according to ISO/DIS 6743-9: ISO-L-XCDHB 2**

Contents	Container	Order no
400 g	Cartridge	9909 217 112
500 g	Screw-type cartridge	9794 000 009
5 kg	Bucket	9909 217 113
15 kg	Hobbock	9909 217 114
25 kg	Bucket	9909 217 115
50 kg	Hobbock	9909 217 116
180 kg	Drum	9909 217 117



### Complex roller bearing grease

special grease for truck axles, for both long-term use and use in high temperature ranges, reduced bearing friction, corrosion and oxidation resistant, offers very good protection against wear, with high pressure absorption capacity

Temperature resistance -30 to +150 °C

Colour blue

Specification MAN 284 Li-H2

#### Application range

Specially suitable for new-generation heavily-loaded ECO axles. Recommended for all applications where BPW axle grease (e.g. ECO LI PLUS) is to be used. EUROPART complex roller bearing grease is also backwards compatible for use on older axles.

**designation according to DIN 51 501: KP 2 N-30**

**designation according to ISO/DIS 6743-9: ISO-L-XCDHB 2**

Contents	Container	Order no
5 kg	Bucket	9909 273 101
15 kg	Hobbock	9909 273 102
25 kg	Bucket	9909 273 103
50 kg	Hobbock	9909 273 104

## Damage diagnosis

Roller bearings are mechanical element with a wide range of uses. They are reliable even under tough conditions, with the result that premature failure is most likely due to the product environment or incorrect assembly. The first indication of roller bearing damage is usually noises, but depending on the usage conditions, it may take months between the start of damage occurring and the actual failure of the bearing. When inspecting damaged bearings, a very wide-range of characteristics can be seen. To find the cause of damage, it is not usually sufficient to observe the bearing alone. Rather, the surrounding components, the lubrication and the sealing as well as the operating and ambient conditions must also be taken into account. A systematic procedure of inspection makes it easier to find the causes.

### Causes of bearing damage and action required

Modern wheel bearings are designed for maximum service life. In optimal conditions, wheel bearings can achieve a very high mileage. However, there are various interference factors, which can significantly influence the life of wheel bearings. These include:

- Road/operating conditions
- Incorrect assembly
- Corrosion
- Assignment errors/incorrect selection
- Incorrect or unsuitable grease
- Product environment/surrounding components

To guarantee correct installation as well as problem-free and reliable function of wheel bearings, factors such as vehicle condition, component environment, cleanliness and the use of special tools must be observed. To meet these requirements, access to the vehicle manufacturer's current technical data must be guaranteed. Information about tightening torques, for example,

are provided to every customer by Schaeffler Automotive Aftermarket via the online portal [www.repxpert.de](http://www.repxpert.de). With proper assembly and taking into consideration the above-mentioned instructions, the risk of premature wheel bearing failure is minimised. In-depth technical knowledge, vehicle-specific expertise as well as a structure procedure are basic requirements for the diagnosis and assessment of roller bearing damage.

### Information regarding roller bearing damage and its causes

Characteristic	Typical causes of roller bearing damage									
	Incorrect assembly	Incorrect tool	Uncleanliness	Excessive preload	Inadequate preload	Too firmly fitted	Too loosely fitted	Incorrect grease	Too little grease	Too much grease
Uneven running	X	X	X	X	X	X	X	X	X	
Noise	X	X	X	X	X	X	X	X	X	
Temperature				X		X		X	X	X
Fatigue damage	X	X	X	X		X	X	X	X	
Hot box damage				X		X	X	X	X	X
Breaks	X	X		X		X				
Frictional corrosion	X				X					
Scoring damage								X	X	
Wear damage		X						X	X	
Corrosion damage	X	X						X		

**EUROPART**  
GOOD TO KNOW

## Damage patterns

Improper assembly results in premature failure of the wheel bearing. Therefore, the use of special tools and observation of the assembly instructions or the vehicle manufacturer's specifications are absolutely required.

### Bearing makes noises

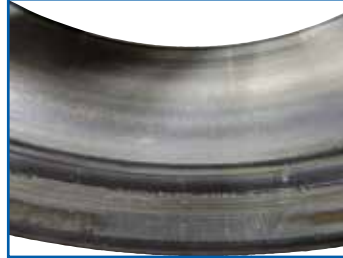
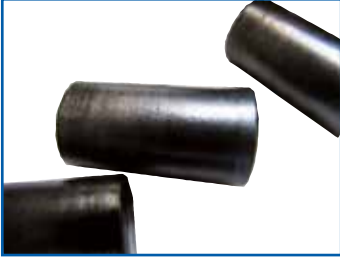

#### Cause:

- Improper assembly/adjustment
- Incorrect or too firm/rigid adjustment of the roller element

#### Impact:

- Temperature increase/hot box
- Roller bearing grease completely consumed

#### Remedy:

- Assemble in accordance with the manufacturer's specifications
- Observe correct adjustment
- Replace hub incl. bearing

### Oil leak at the wheel hub



#### Cause:

- Damage to the seal (shaft seal) due to improper assembly

#### Impact:

- Due to damage to the shaft seal, oil gets into the bearing.
- All of the grease is washed out, lubrication is no longer guaranteed.
- The bearing surfaces are exposed to increased wear.

#### Remedy:

- Observe the manufacturer's assembly instructions
- Use of the special tool is absolutely required
- Replace the bearing

### Leak at the wheel hub



#### Cause:

- Bearing dismantled before assembly (closed unit)
- Bearing removed and refitted again

#### Impact:

- Function of the seal (shaft seat) is no longer guaranteed.
- Oil enters the bearing
- grease erosion

#### Remedy:

- Replace bearing
- Do not dismantle closed units

### Bearing makes noises



**Cause:**

- Position too low

**Impact:**

- Contact pattern/contact width of the rolling element not correct or too narrow
- Incorrect load on inner ring (frictional corrosion)

**Remedy:**

- Use the prescribed tightening torque – see [www.rexpert.de](http://www.rexpert.de)
- Before assembly, check the condition of the hub.
- Replace hub and bearing

### Premature failure of the wheel bearing



**Cause:**

- Incorrect or too tight adjustment

**Impact:**

- Start of hot boxes
- Deficient lubrication

**Remedy:**

- Use the prescribed tightening torque – see [www.rexpert.de](http://www.rexpert.de)
- Replace bearing, check hub condition

### Wheel hub worn



**Cause:**

- Bearing or outer ring has rotated in the hub

**Impact:**

- Incorrect fit
- Visible incorrect load on inner ring (frictional corrosion)

**Remedy:**

- Check hub condition before assembly
- Check all surrounding components
- Replace hub and bearing

### Failure of the wheel bearing

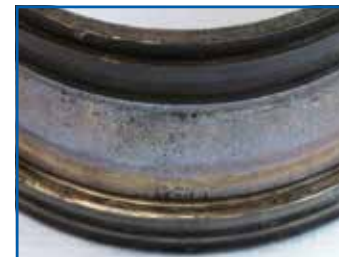

**Cause:**

- Increased axial play
- Inadequate preloading of the bearing

**Impact:**

- High torque and axial load on the inner bearing with the result that the tapered rollers at the board rise and restrict.
- In the further damage progression, increased temperatures occur and the lubricating grease flows out while at the same time the base oil evaporates.

**Remedy:**

- Replace bearing
- Check condition of wheel hub, replace if necessary

# Useful guidelines for use

## Bearing clearance

Bearing clearance can be defined as the total distance by which a bearing ring can be moved relative to another bearing ring in radial (radial bearing clearance) or axial (axial clearance) direction.

In addition, a distinction is also made between the bearing clearance (design-based) before installation and the bearing clearance once installed under actual operating conditions (operating clearance).

The bearing clearance before installation is therefore greater than the operating clearance, as the different press fits and thermal expansions of

the bearing rings and the associated components result in an expansion or contraction of the rings.

Depending on the area of use, it may be necessary to adjust a positive or negative bearing clearance. In most applications, the operating clearance should be positive, i.e. during operation, there should still be a slight residual bearing clearance in the bearing.

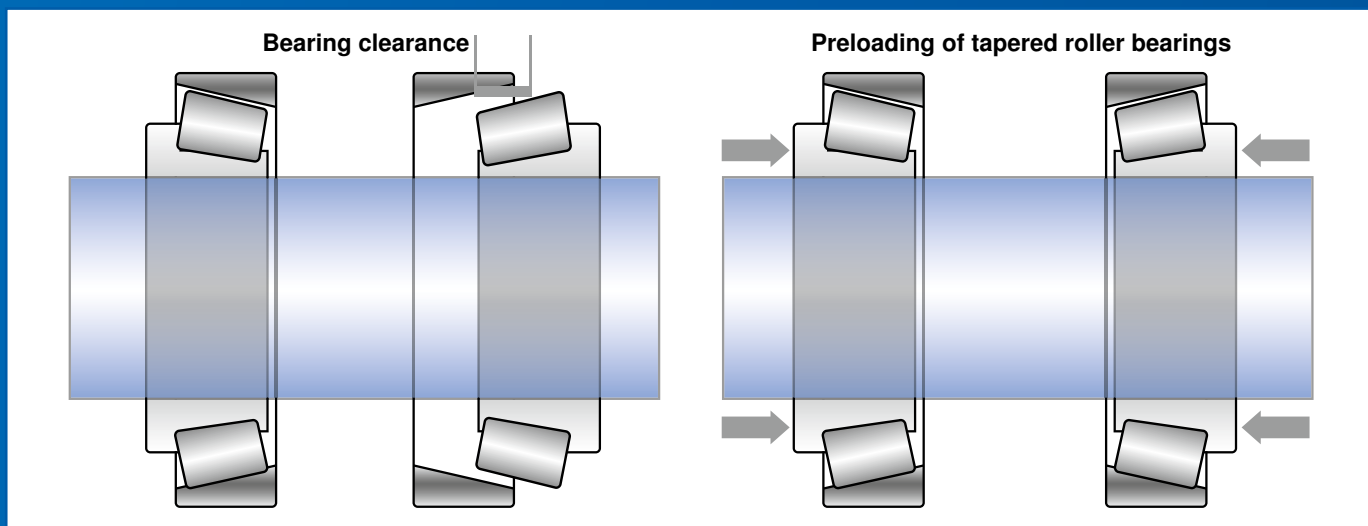

## Preloading of tapered roller bearings

A negative bearing clearance, also called preload, takes effect when the rigidity of the bearing arrangement needs to be improved or the running precision needs to be increased. All pre-assembled units from FAG are designed to be installed preloaded.

### The main reasons for a preload are:

- To increase rigidity
- To reduce running noise
- Long service life

With single-row tapered roller bearings, the bearing clearance is only created after installation and is dependent on the adjustment against the bearing, which acts as the counter-guide.

**EUROPART**  
GOOD TO KNOW

## Adjusting tapered roller bearings

By bearing adjustment, we mean a defined tensioning of the two bearings compared to each other.

To do this, you push a bearing ring of two inversely installed tapered roller bearings on its seat until the bearing has the desired clearance or preload. The radial clearance and axial clearance change simultaneously in a specific ratio. This ratio depends on the contact angle of the bearing.

For mutual adjustment of tapered roller bearings, the wheel must be turned so that the rollers can fall into their correct position, i.e. the large end face of the rollers must be positioned at the guide board.

### Why is the preload important?

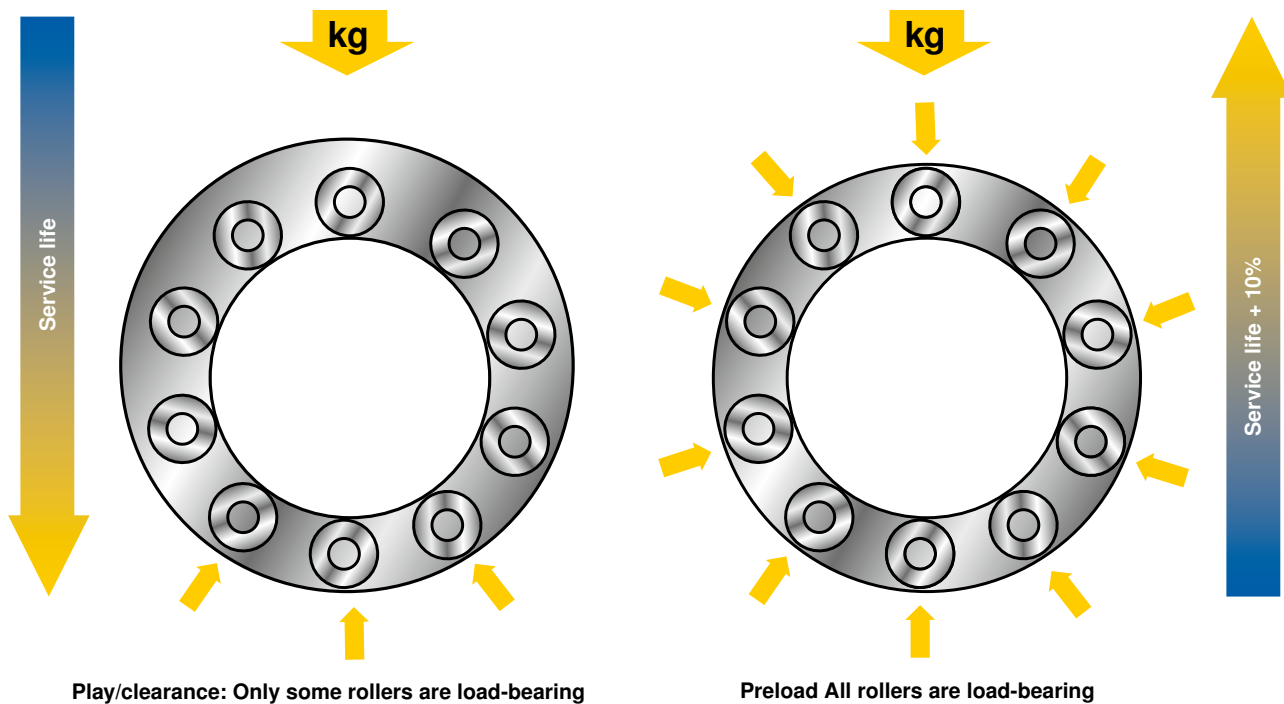

**EUROPART**  
GOOD TO KNOW

## Checking the hub condition (oval deformation)

Both the surrounding components and the wheel hub must always be checked for functionality and wear.

Checking of the wheel hub condition (oval deformation) can be done in various ways:

### 1st variant

- Both inner rings with cage and rolling element have been knocked out of the hub. Only the outer rings remain in the hub.
- Use a suitable tool to press out the outer rings (tool can be obtained from us).
- Clean the hub and place under a press.
- Slowly press out the outer ring. The pressure at the press must not fall below 0.5 t. If it falls below this value, replace the hub.

### 2nd variant

- Both inner rings with cage and rolling element have been knocked out of the hub. Only the outer rings remain in the hub.
- Clean the hub.
- Drive out the outer ring with a suitable brass mandrel.
- Check whether the outer ring surface has a dark stain on each of two opposite sides.

Check whether the two surfaces, which are at an angle of 90° from the dark stains, are undamaged. If this is the case, the locating bore is deformed and the wheel hub must be replaced (see images).



Wheel hub OK



Oval deformation – Wheel hub not OK

**EUROPART**  
GOOD TO KNOW

## Assembly advantages of wheel bearing units vs. standard tapered roller bearings

	Assembly steps			
	Required tool for disassembly and assembly	1st step	2nd step	
Wheel bearing designs	Standard tapered roller bearing (TRB)	<ul style="list-style-type: none"> <li>– Suitable striking out tool for outer rings</li> <li>– Assembly tools for shaft seals</li> <li>– Dial gauge depending on the vehicle manufacturer</li> <li>– Torque wrench</li> </ul>	<ul style="list-style-type: none"> <li>– Check wheel hub for oval deformation</li> <li>– See also "Checking the hub condition (oval deformation)" on page 44</li> </ul>	<ul style="list-style-type: none"> <li>– Fit outer rings</li> </ul>
	SmartSET	<ul style="list-style-type: none"> <li>– Suitable striking out tool for outer rings</li> <li>– Assembly tools for shaft seals</li> <li>– Dial gauge depending on the vehicle manufacturer</li> <li>– Torque wrench</li> <li>– Metal plate in size of special tool</li> </ul>	<ul style="list-style-type: none"> <li>– Check wheel hub for oval deformation</li> <li>– See also "Checking the hub condition (oval deformation)" on page 44</li> </ul>	<ul style="list-style-type: none"> <li>– Press inner and outer bearing into the wheel hub using supplied tool and additional metal plate</li> </ul>
	Insert Unit (IU)	<ul style="list-style-type: none"> <li>– Suitable brass bar</li> <li>– Assembly tool for shaft seals</li> <li>– Dial gauge</li> <li>– Torque wrench</li> </ul>	<ul style="list-style-type: none"> <li>– Check wheel hub for oval deformation</li> <li>– See also "Checking the hub condition (oval deformation)" on page 44</li> </ul>	<ul style="list-style-type: none"> <li>– Fit outer rings</li> </ul>
	Repair Insert Unit (RIU)	<ul style="list-style-type: none"> <li>– Metal plate the same size as the special tool</li> <li>– Torque wrench</li> </ul>	<ul style="list-style-type: none"> <li>– Check wheel hub for oval deformation</li> <li>– See also "Checking the hub condition (oval deformation)" on page 44</li> </ul>	<ul style="list-style-type: none"> <li>– Press inboard and outboard bearing into the wheel hub using supplied tool and metal plate</li> </ul>
	Truck Hub Unit (THU)	<ul style="list-style-type: none"> <li>– Press-in plate in the same size as the external diameter of the bearing</li> <li>– Torque wrench</li> </ul>	<ul style="list-style-type: none"> <li>– Check wheel hub for oval deformation</li> <li>– See also "Checking the hub condition (oval deformation)" on page 44</li> </ul>	<ul style="list-style-type: none"> <li>– With press-in plate over the outer ring, press the wheel bearing unit into the wheel hub</li> </ul>
	Truck Axle Module (TAM)	<ul style="list-style-type: none"> <li>– Torque wrench</li> </ul>	<ul style="list-style-type: none"> <li>– Assembly the wheel hub on the brake disc</li> </ul>	<ul style="list-style-type: none"> <li>– Place brake disc incl. wheel hub on the axle shaft</li> </ul>

## Assembly steps

3rd step	4th step	5th step	6th step	7th step
<ul style="list-style-type: none"> <li>– Grease wheel bearing before assembly</li> </ul>	<ul style="list-style-type: none"> <li>– Insert inner rings with rollers and cage</li> <li>– Fit shaft seals</li> </ul>	<ul style="list-style-type: none"> <li>– Fit wheel hub</li> <li>– Ensure that the shaft seals are not damaged</li> </ul>	<ul style="list-style-type: none"> <li>– Tighten the axle nuts according to the manufacturer's instructions</li> </ul>	<ul style="list-style-type: none"> <li>– Adjust the bearing play/preload</li> </ul>
<ul style="list-style-type: none"> <li>– Fit wheel hub</li> <li>– Ensure that the shaft seal is not damaged</li> </ul>	<ul style="list-style-type: none"> <li>– Tighten the axle nuts according to manufacturer's specifications</li> <li>– Check bearing play/preload and adjust if necessary</li> </ul>			
<ul style="list-style-type: none"> <li>– Grease wheel bearing before assembly</li> </ul>	<ul style="list-style-type: none"> <li>– Insert inner rings with rollers and cage</li> <li>– Fit shaft seals</li> </ul>	<ul style="list-style-type: none"> <li>– Fit wheel hub</li> <li>– Ensure that the shaft seals are not damaged</li> </ul>	<ul style="list-style-type: none"> <li>– Tighten the axle nuts according to the manufacturer's instructions</li> </ul>	<ul style="list-style-type: none"> <li>– Adjust the bearing play/preload</li> </ul>
<ul style="list-style-type: none"> <li>– Fit wheel hub</li> <li>– Ensure that the O-rings are not damaged</li> </ul>	<ul style="list-style-type: none"> <li>– Tighten the axle nuts according to the manufacturer's instructions</li> </ul>			
<ul style="list-style-type: none"> <li>– Fit wheel hub</li> <li>– Ensure that the O-rings are not damaged</li> </ul>	<ul style="list-style-type: none"> <li>– Tighten the axle nuts according to the manufacturer's instructions</li> </ul>			
<ul style="list-style-type: none"> <li>– Tighten the axle nuts according to the manufacturer's instructions</li> </ul>				

# **EUROPART – international partner for the workshop**

**300 locations in 28 countries**

Find your nearest EUROPART sales outlet at:  
**[www.europart.net](http://www.europart.net)**

